

# NSWGR Z20 7mm Tank Loco Kit

## Locomotive Frame

**Outcome** ---- Completed square and true Locomotive Chassis/Frame with smooth running capabilities

The frame was designed using an 0.55 mm Nickel Silver Etch and is soldered together.

The left and right side vary slightly, and attention needs to be paid to this as they are indicated - left and right.

There are various small parts that make up the Chassis/Frame and they are numbered in the etch.

These parts will only fit into the locations shown in the instructions. Do Not force them but rub then down with fine wet and dry paper and ease them into position.

The frame is constructed in an Etched Nickel Silver Jig which needs to be constructed prior to the construction of the loco frame. As this needs to be done first let us make a start on that process.

The construction method in this kit is the same as all my other kits in the KRM Range, that is the part profiles are indicated at the top left of the page, and the parts are put together in sequence, with the previous part Coloured in GREY and the new part Coloured in PURPLE. This is a standard.

# NSWGR Z20 7mm Tank Loco Kit

## Chassis/Frame Jig Construction \_Step\_01



There are also 12 Brass Lace pins which are used to secure the etch onto a timber plinth to allow the jig to be as stable as possible.

There is also a 30 mm section of 1 mm wire and a 30 mm section of 1.5 mm wire with the jig.

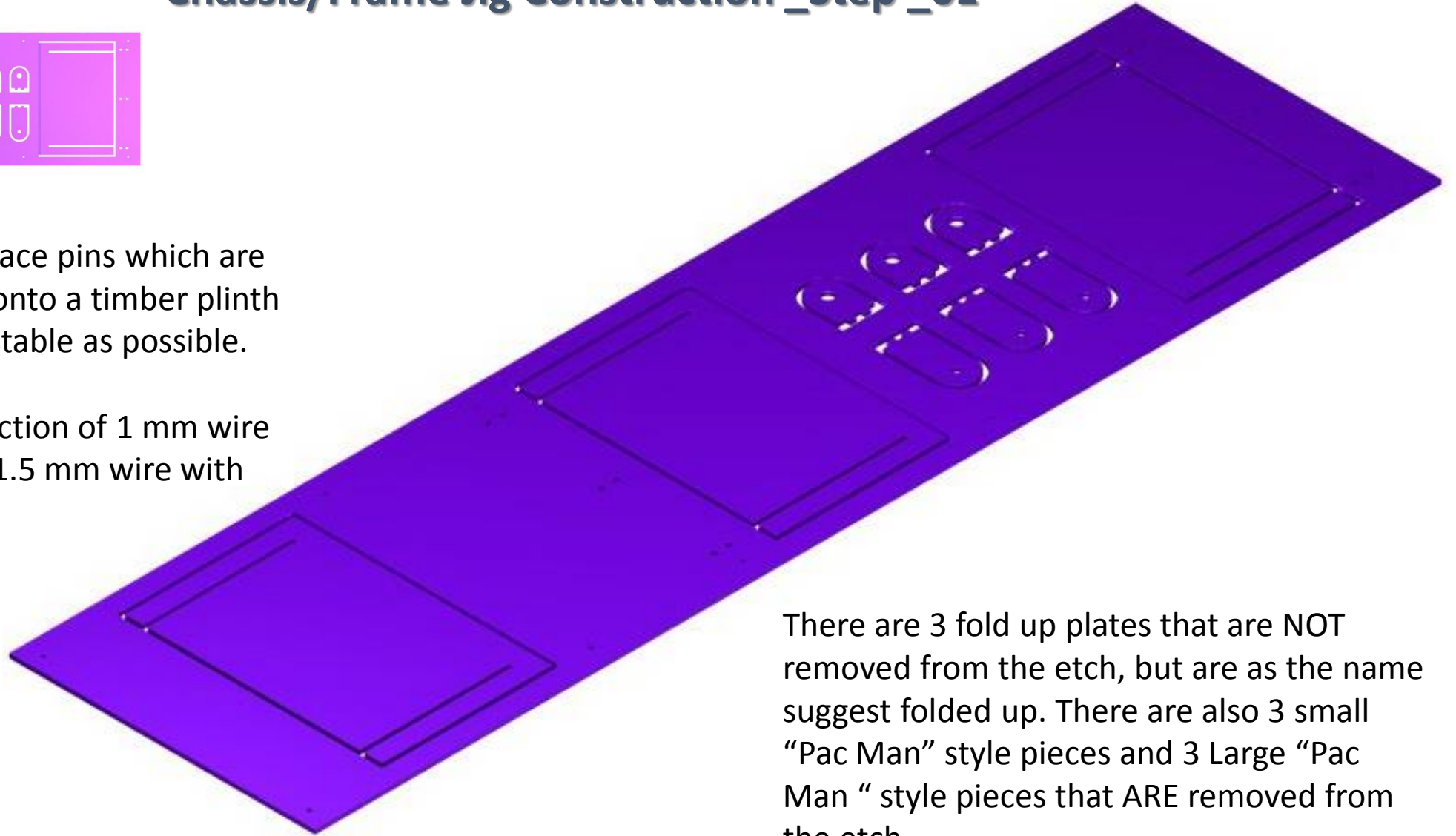

There are 3 fold up plates that are NOT removed from the etch, but are as the name suggest folded up. There are also 3 small “Pac Man” style pieces and 3 Large “Pac Man “ style pieces that ARE removed from the etch.

# NSWGR Z20 7mm Tank Loco Kit

## Chassis/Frame Jig Construction \_Step\_02



The 3 fold ups are folded at their fold lines to that they sit at 90 degrees to the base of the jig, try not to distort the etch during this process, and use a hobby knife to start the folding process by getting under the front of each fold up and prying it upwards.

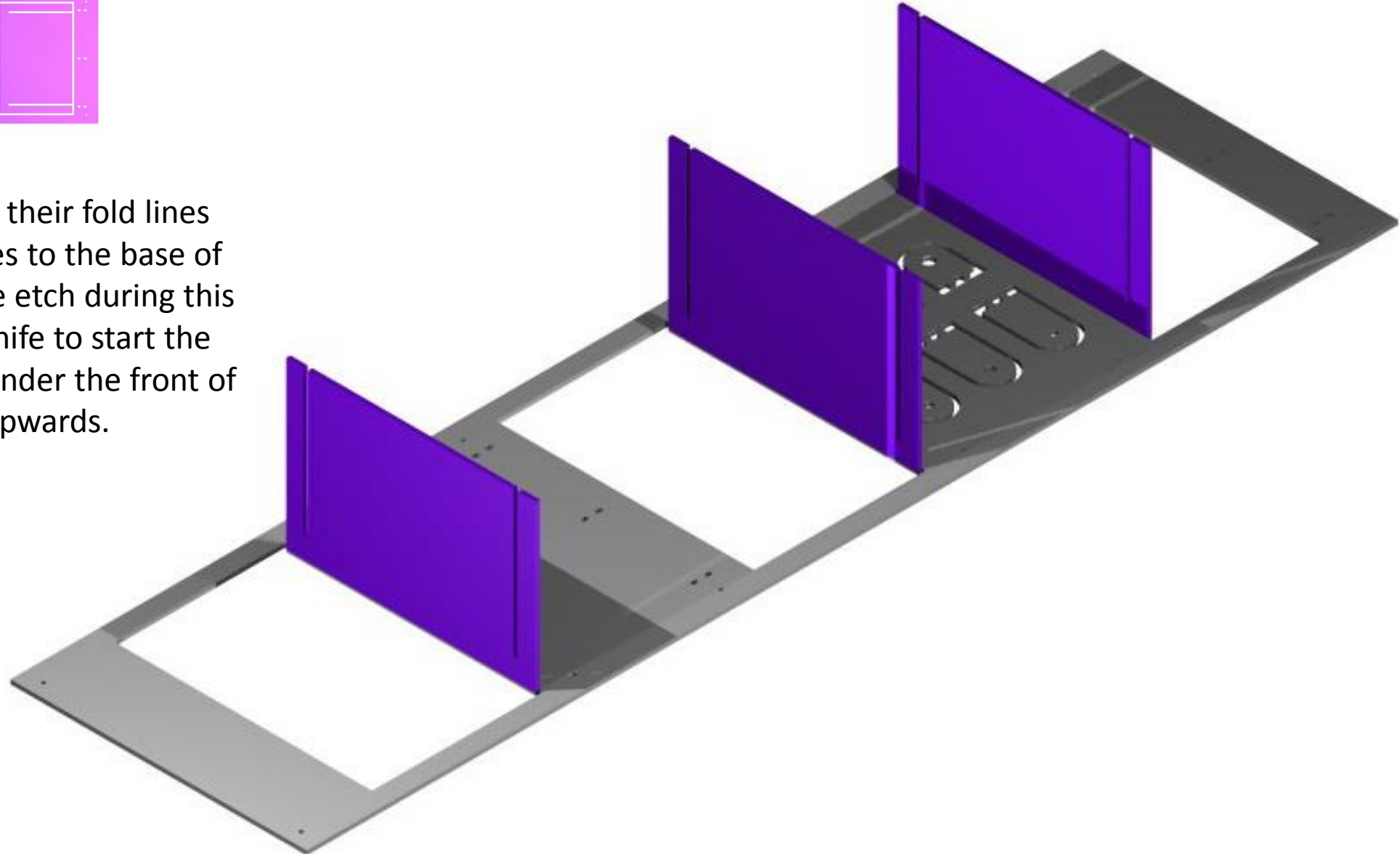

# NSWGR Z20 7mm Tank Loco Kit

## Chassis/Frame Jig Construction \_Step\_03



The 3 smaller “Pac Men” are located and soldered into the holes as indicated at this position. These locate the etched frames so that should set square to the jig using a 1.5 mm length of wire.

The larger “Pac Men” are fitted toward the front of the etch and do a similar job as the smaller pieces, and they use a 1 mm diameter length of brass wire.

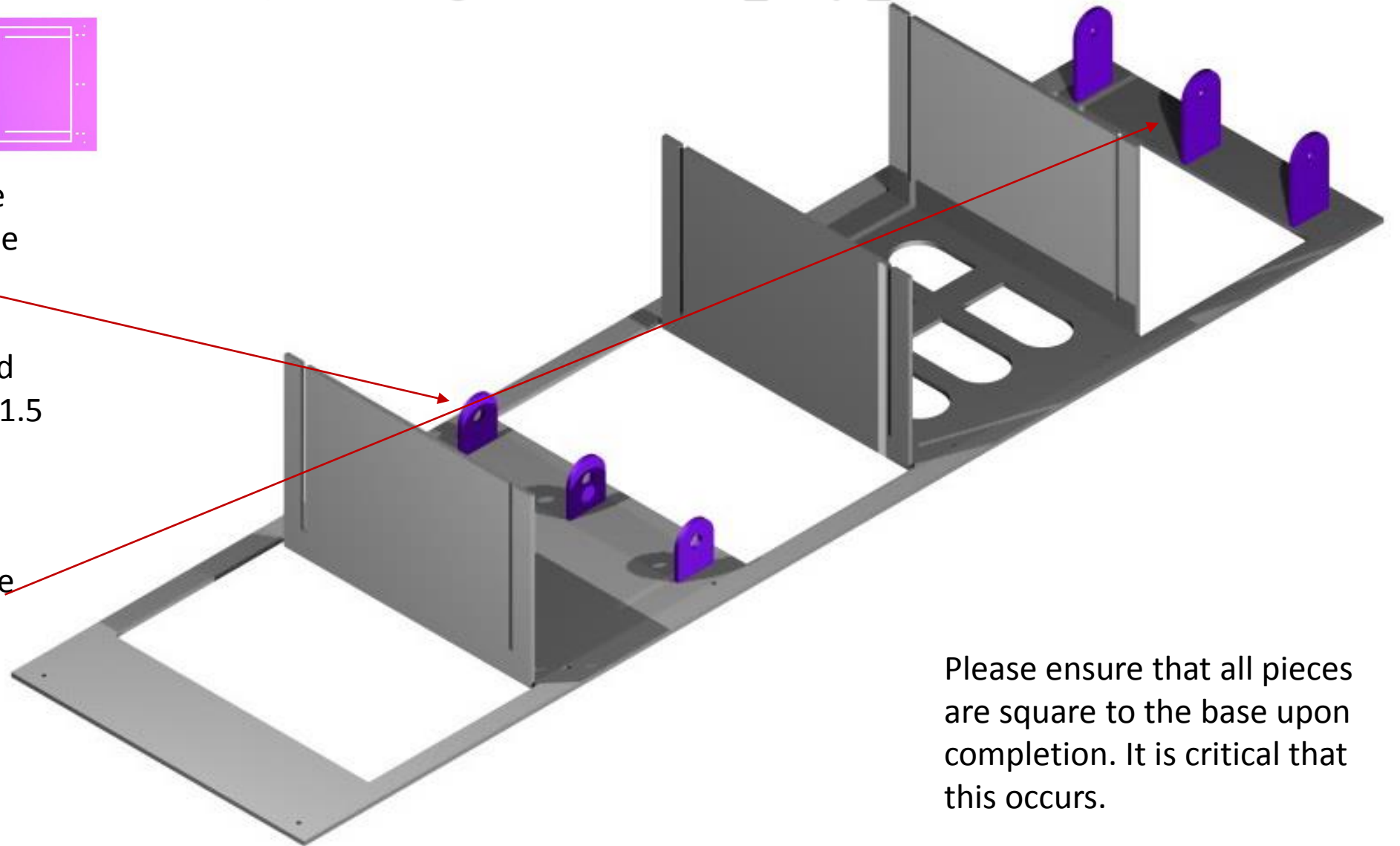

Please ensure that all pieces are square to the base upon completion. It is critical that this occurs.

# NSWGR Z20 7mm Tank Loco Kit

## Chassis/Frame Jig Construction \_Step\_04



Place the completed Jig onto a timber plinth (of your choosing) and drill the locations for the Lace Pins to hold the jig onto the timber. Make sure that in the process of securing the jig to the timber that there is no distortion of the jig, and also make sure that all vertical pieces are square to the base of the jig.

Trial fit the brass wires through the Holes in the “Pac Men” and ensure that the wire is parallel to the base.

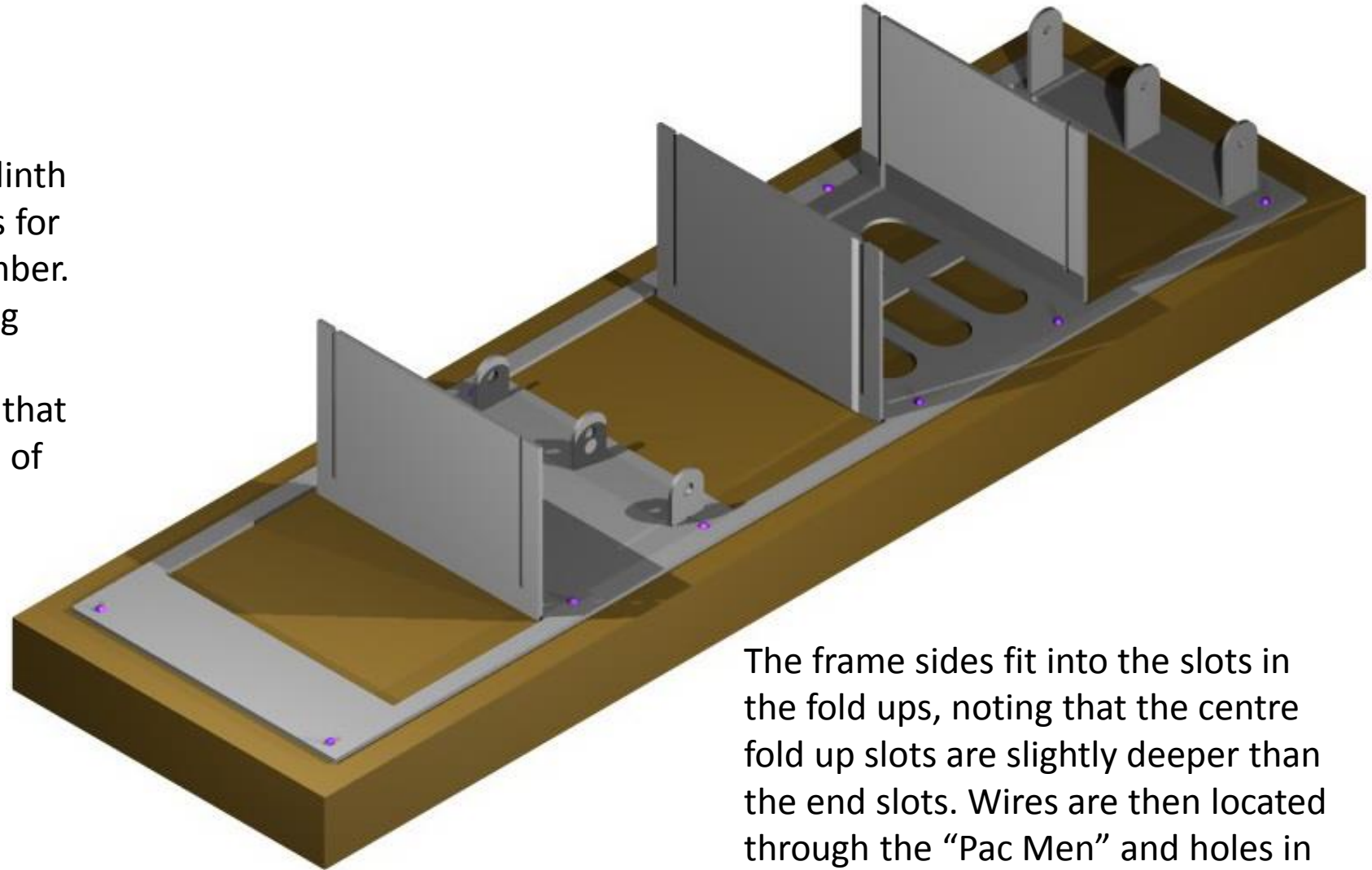

The frame sides fit into the slots in the fold ups, noting that the centre fold up slots are slightly deeper than the end slots. Wires are then located through the “Pac Men” and holes in the Frames indicated in future slides.

# NSWGR Z20 7mm Tank Loco Kit

## Chassis/Frame Jig Construction \_Step\_05

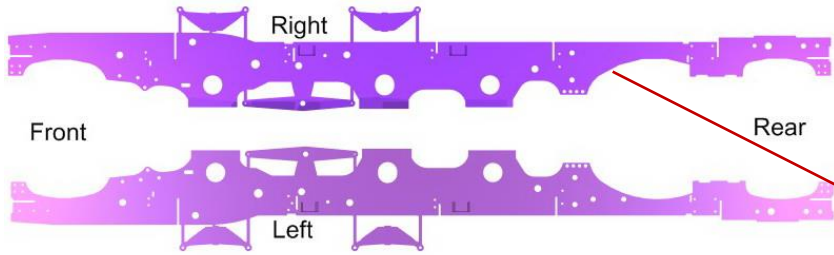

Locate the right hand frame into the jig checking that the base of the frame is free from the cusp in the etch, also make sure that there is no cusp in the slot of the jig, wipe the inside of the jig with a hobby knife blade to remove any cusps or rough edges.

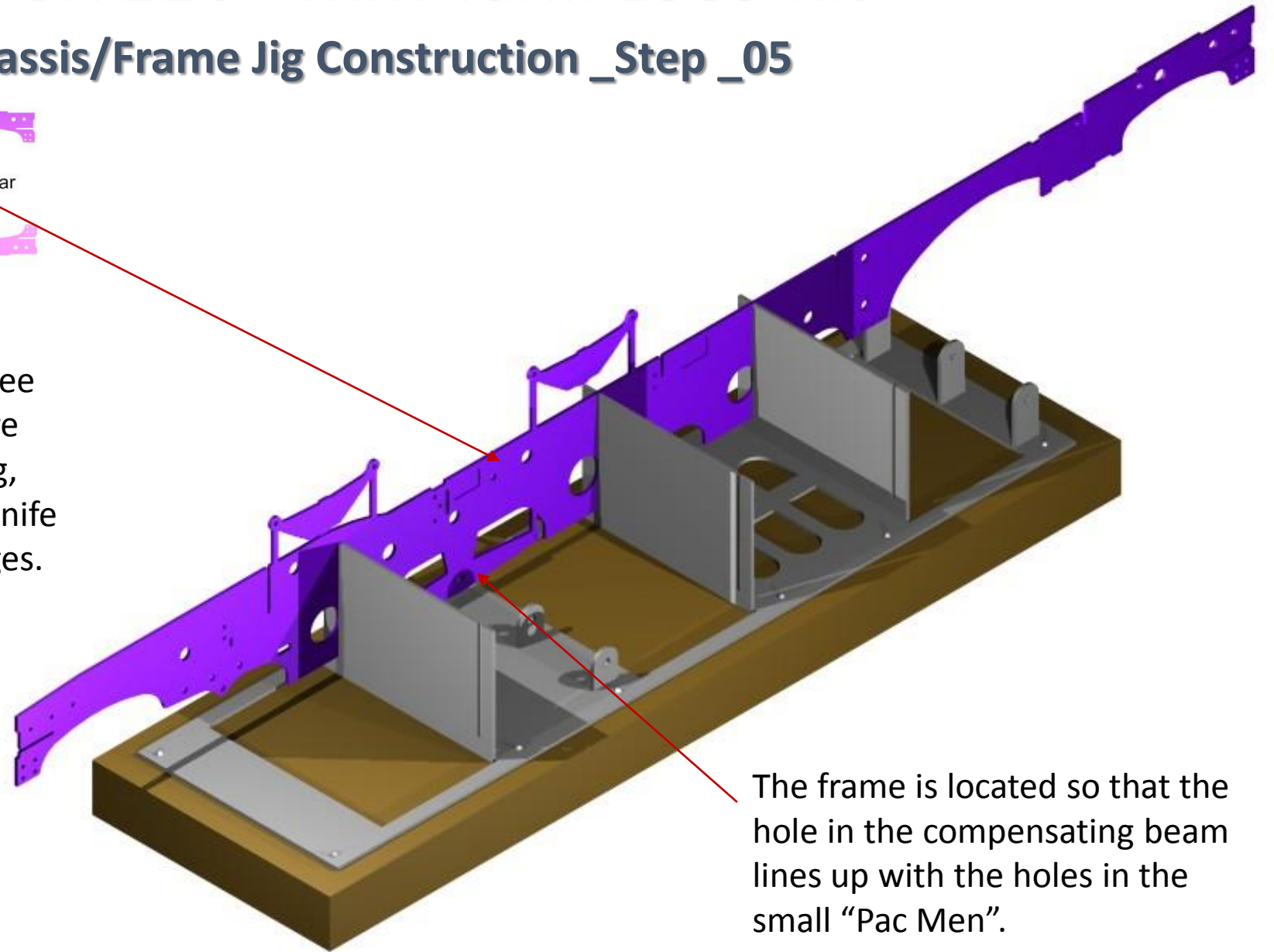

The frame is located so that the hole in the compensating beam lines up with the holes in the small "Pac Men".



# NSWGR Z20 7mm Tank Loco Kit

## Chassis/Frame Jig Construction \_Step\_07

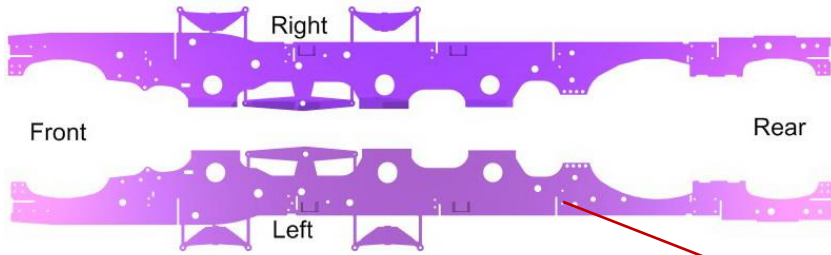

The left hand frame is fitted next and another 3 x 2 mm screws are used to loosely secure the frame to the spacers.

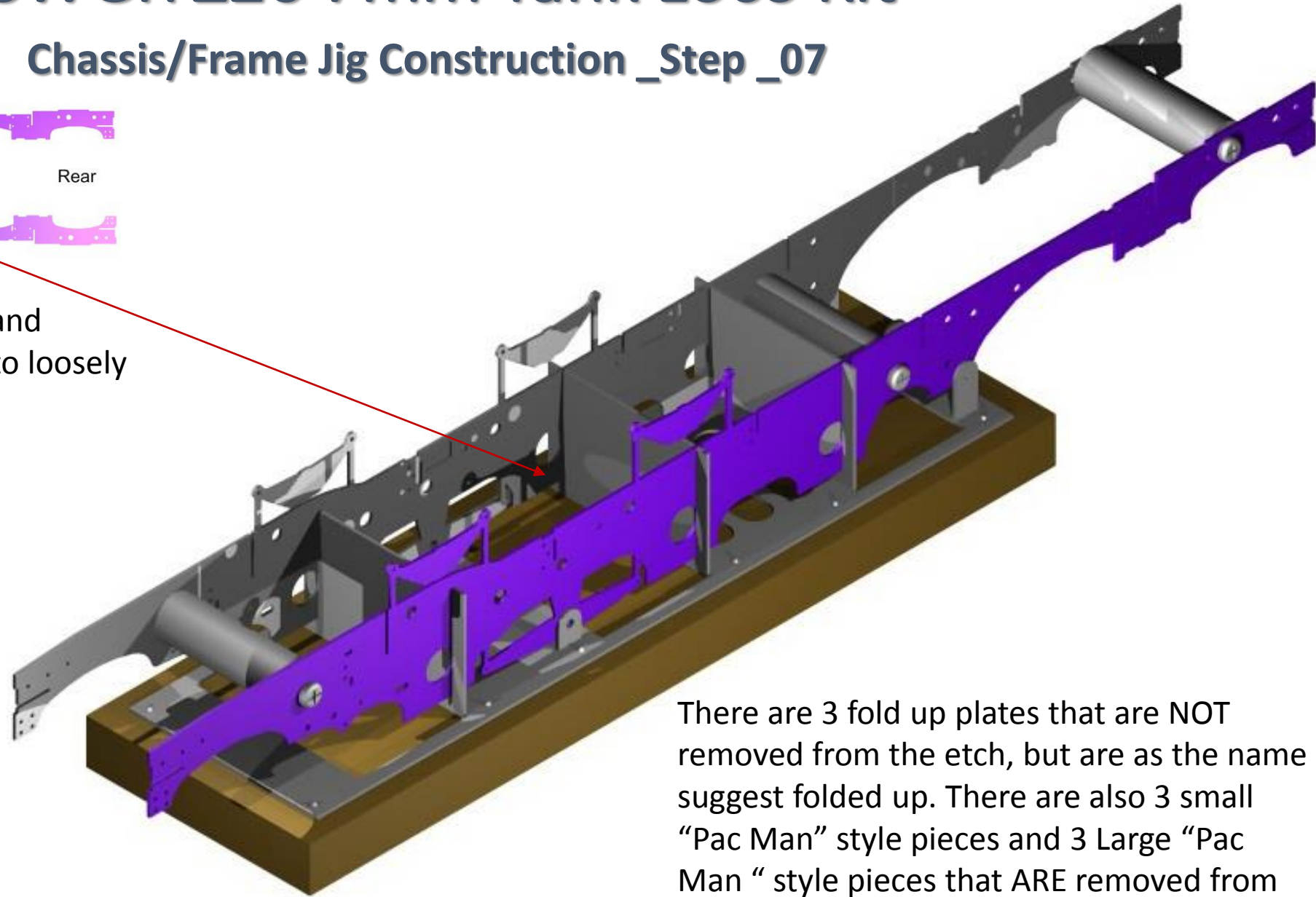

There are 3 fold up plates that are NOT removed from the etch, but are as the name suggest folded up. There are also 3 small "Pac Man" style pieces and 3 Large "Pac Man" style pieces that ARE removed from the etch.

# NSWGR Z20 7mm Tank Loco Kit

## Chassis/Frame Jig Construction \_Step\_08

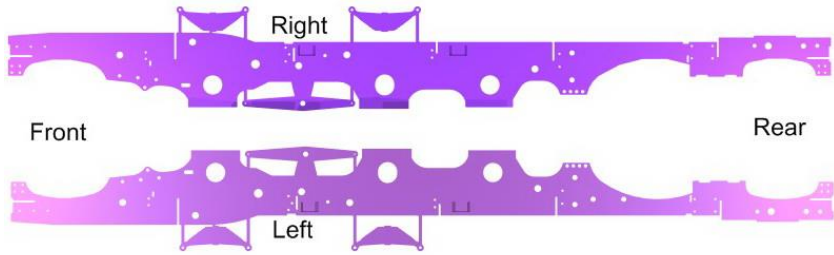

The 1 mm and 1.5 mm brass rods are located into the jig to make sure that the frames are correctly aligned.

The spacers can now be secured by tightening the 6 x 2 mm screws.

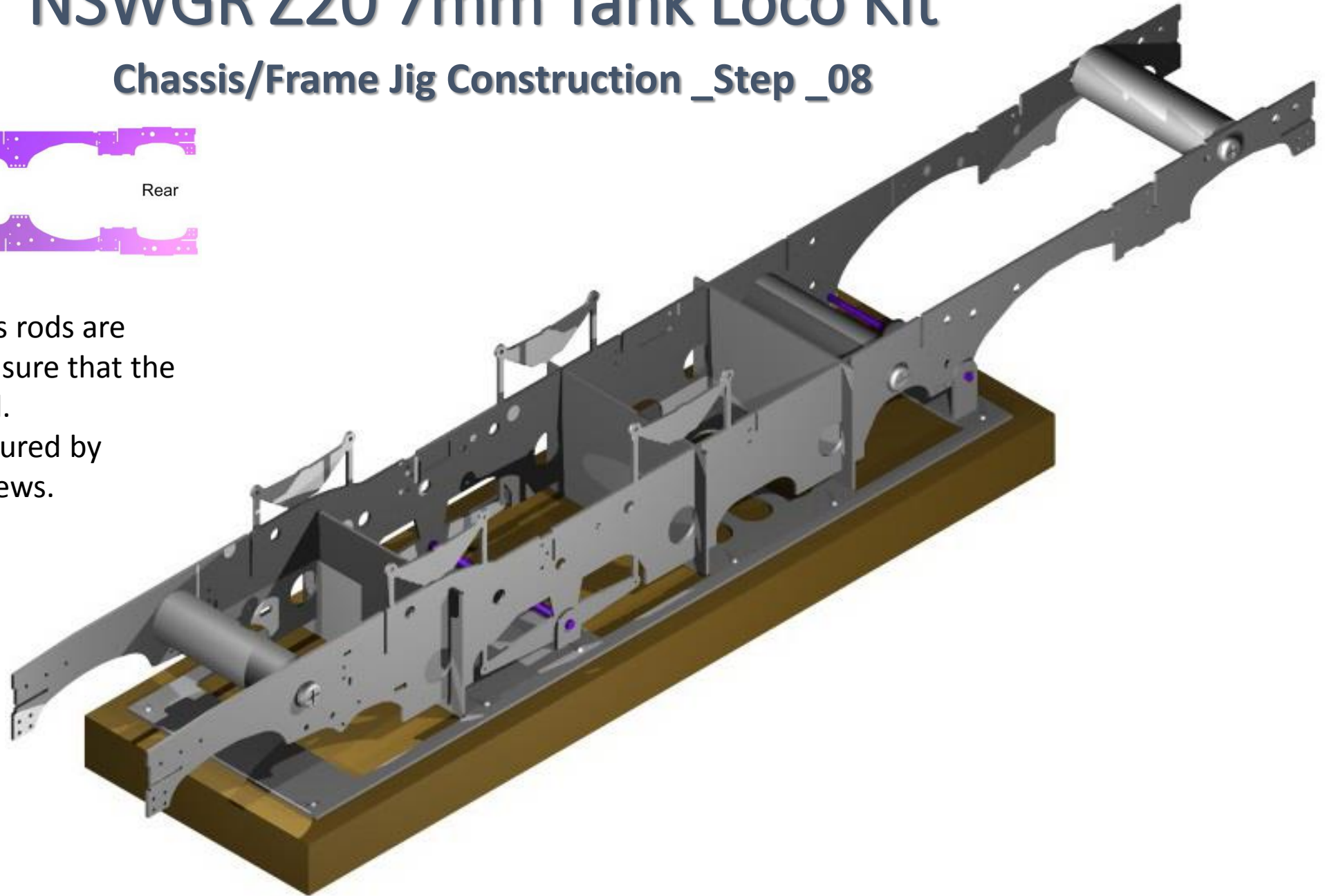

# NSWGR Z20 7mm Tank Loco Kit

## Chassis/Frame Jig Construction \_Step\_09

Panel 1 is folded and fitted to the frames, you may need to release the screws at the front to ensure that the panel fits neatly into place.

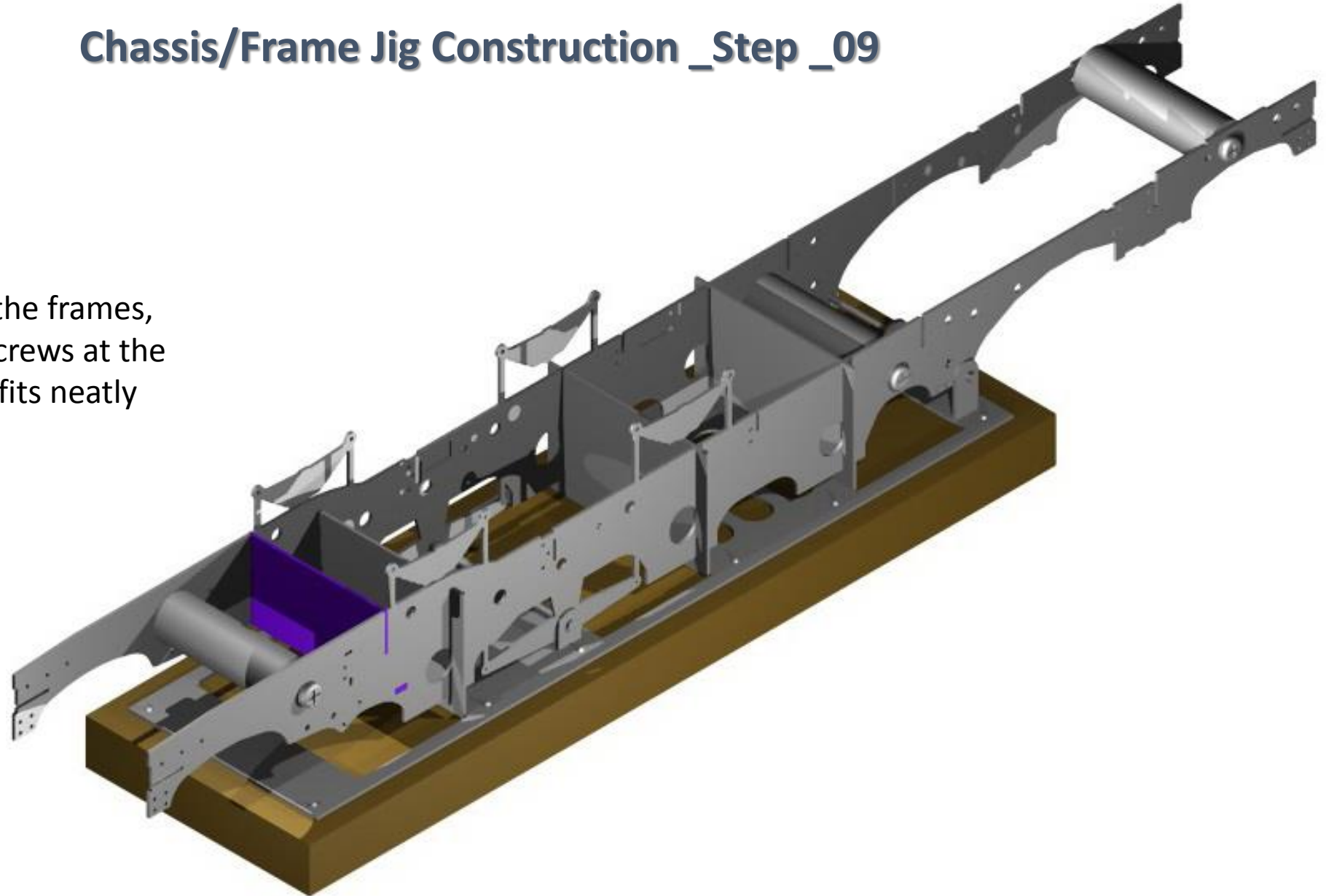

# NSWGR Z20 7mm Tank Loco Kit

## Chassis/Frame Jig Construction \_Step\_10

Panel 2 is fitted next, and this panel should fall into place without the spacer being loosened.

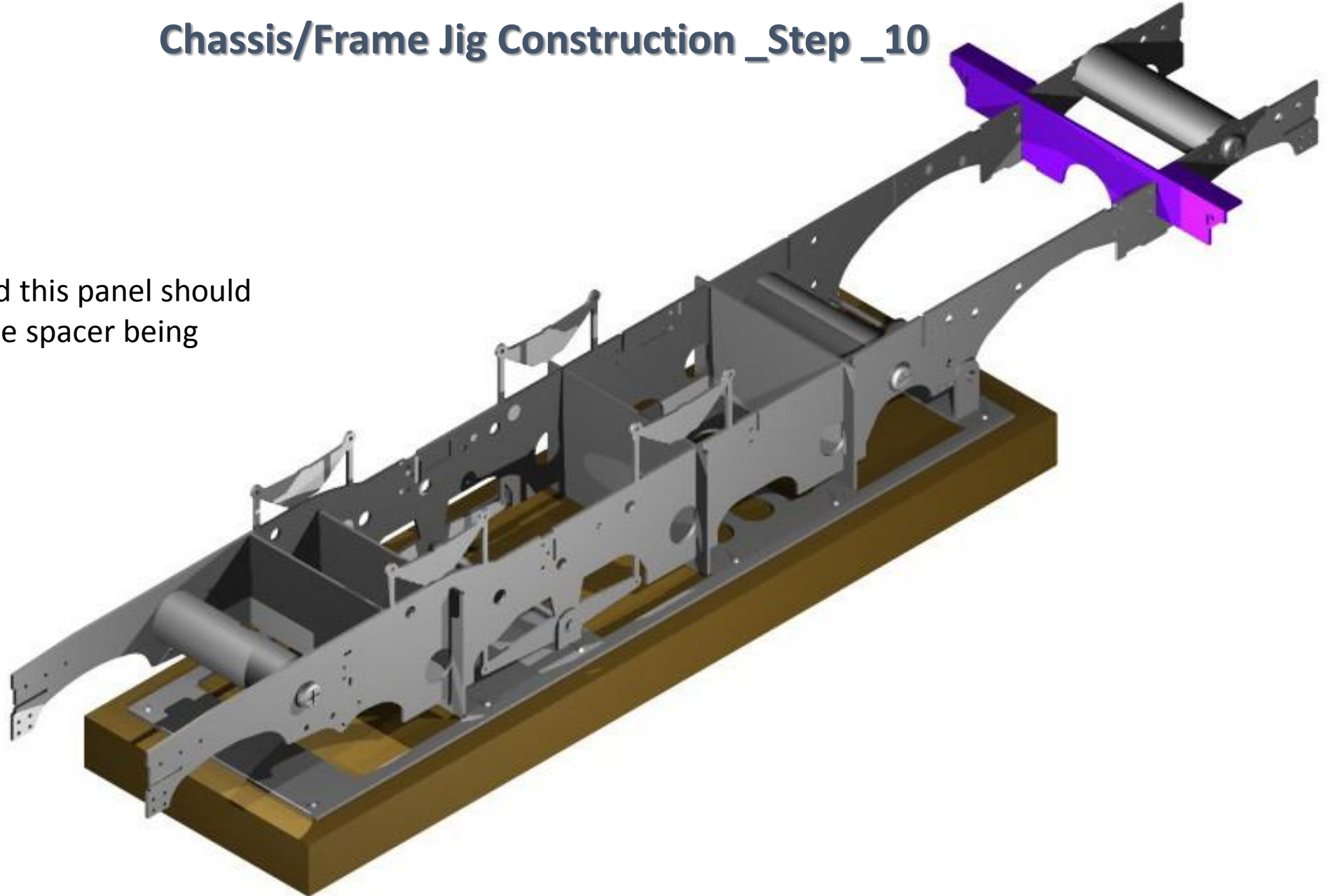

# NSWGR Z20 7mm Tank Loco Kit

## Chassis/Frame Jig Construction \_Step \_12

Panel 3 (the boiler mount) fits in next and should fit snugly into the slots provided for it. The top of the panel should be flush with the top of the frames.

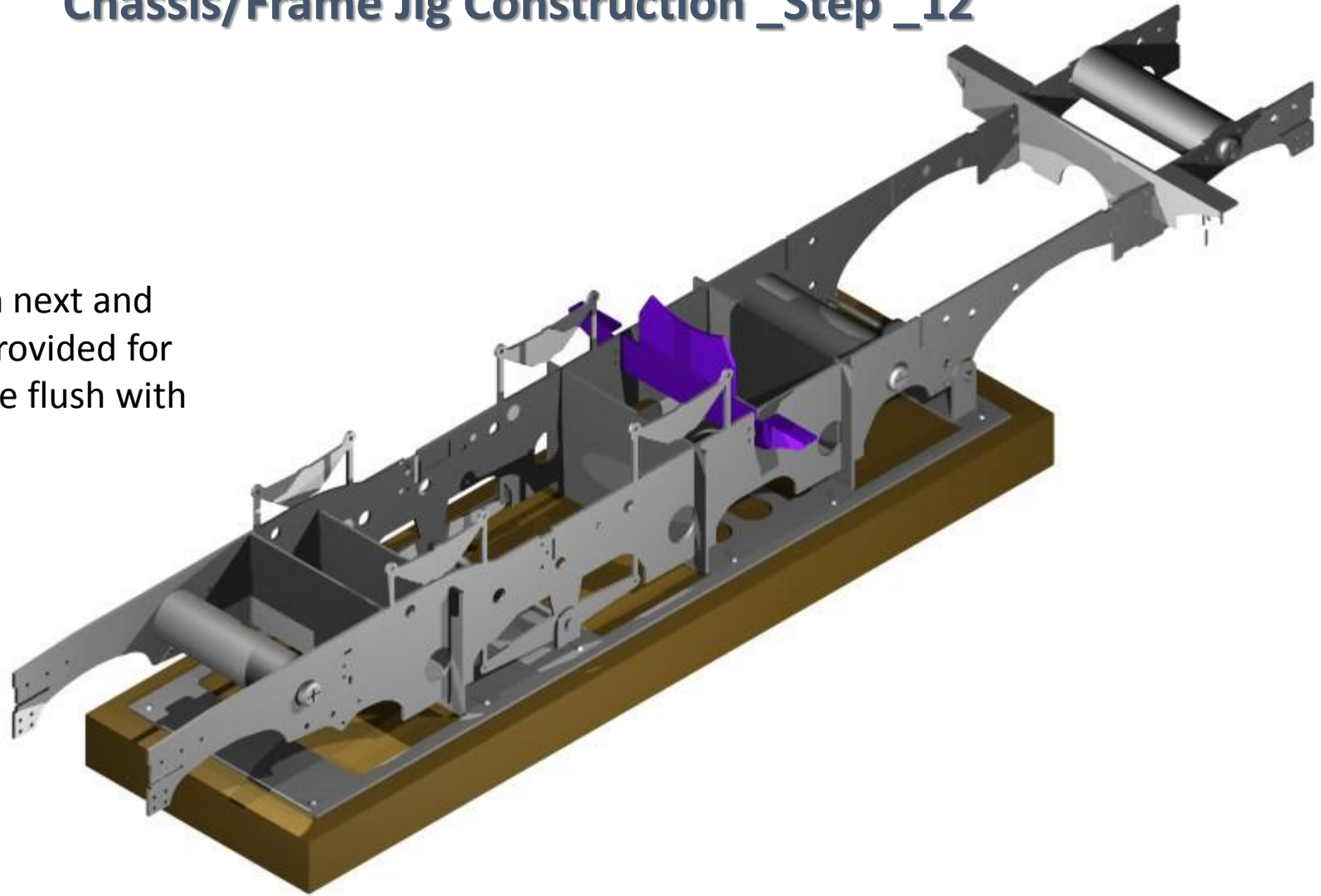

# NSWGR Z20 7mm Tank Loco Kit

## Chassis/Frame Jig Construction \_Step \_13

Panel 4 is next and this panel should also sit flush with the top of the frames. It has other panels attached to it that assist in locating the tanks and footplate.

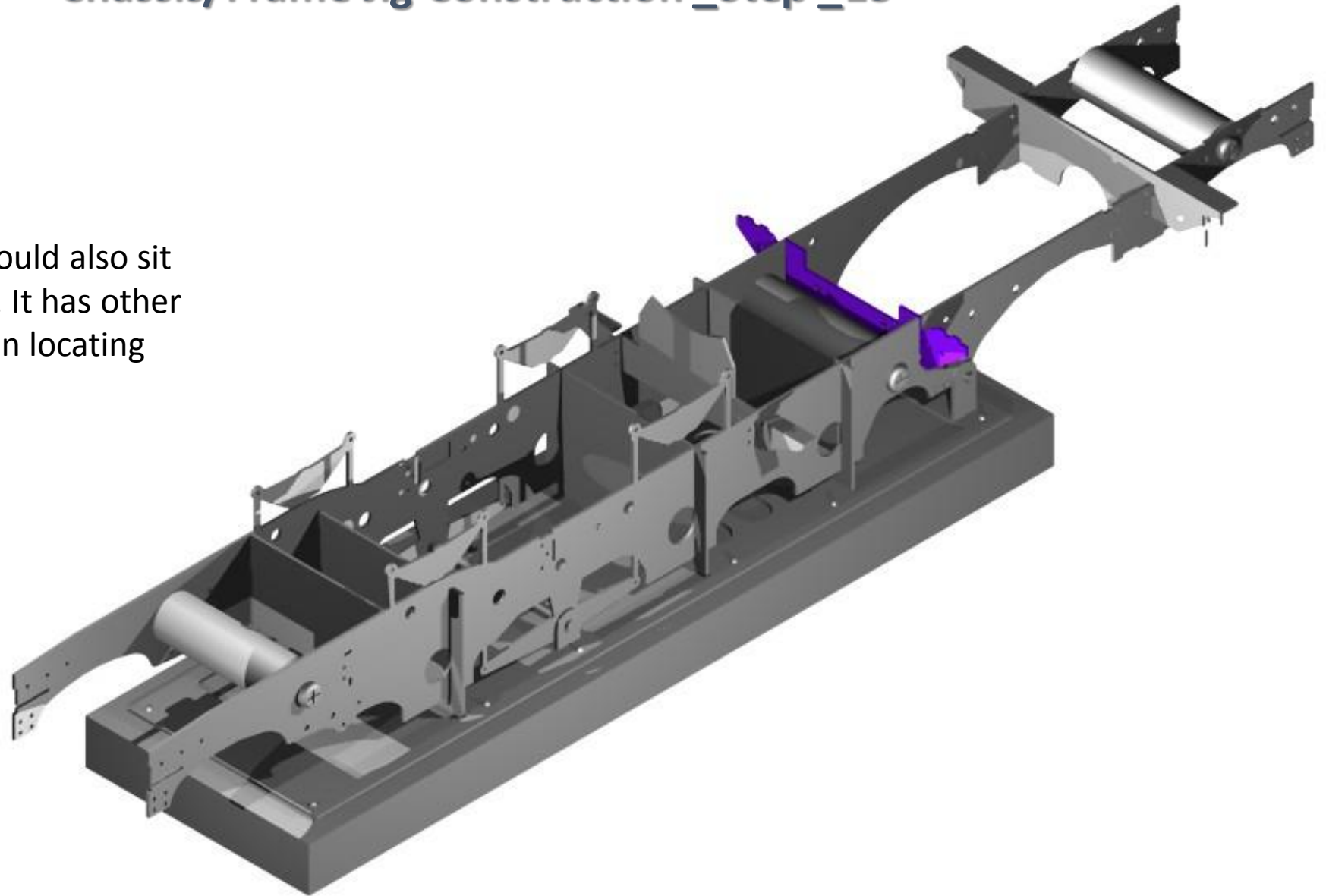

# NSWGR Z20 7mm Tank Loco Kit

## Chassis/Frame Jig Construction \_Step \_14

Panel 5 is fitted to the rear of the frames and has the hole for the 3 link coupler pivot, etched into it. it should sit flush with the rear of the frames except for a couple of tabs that are attached to the buffet panel.

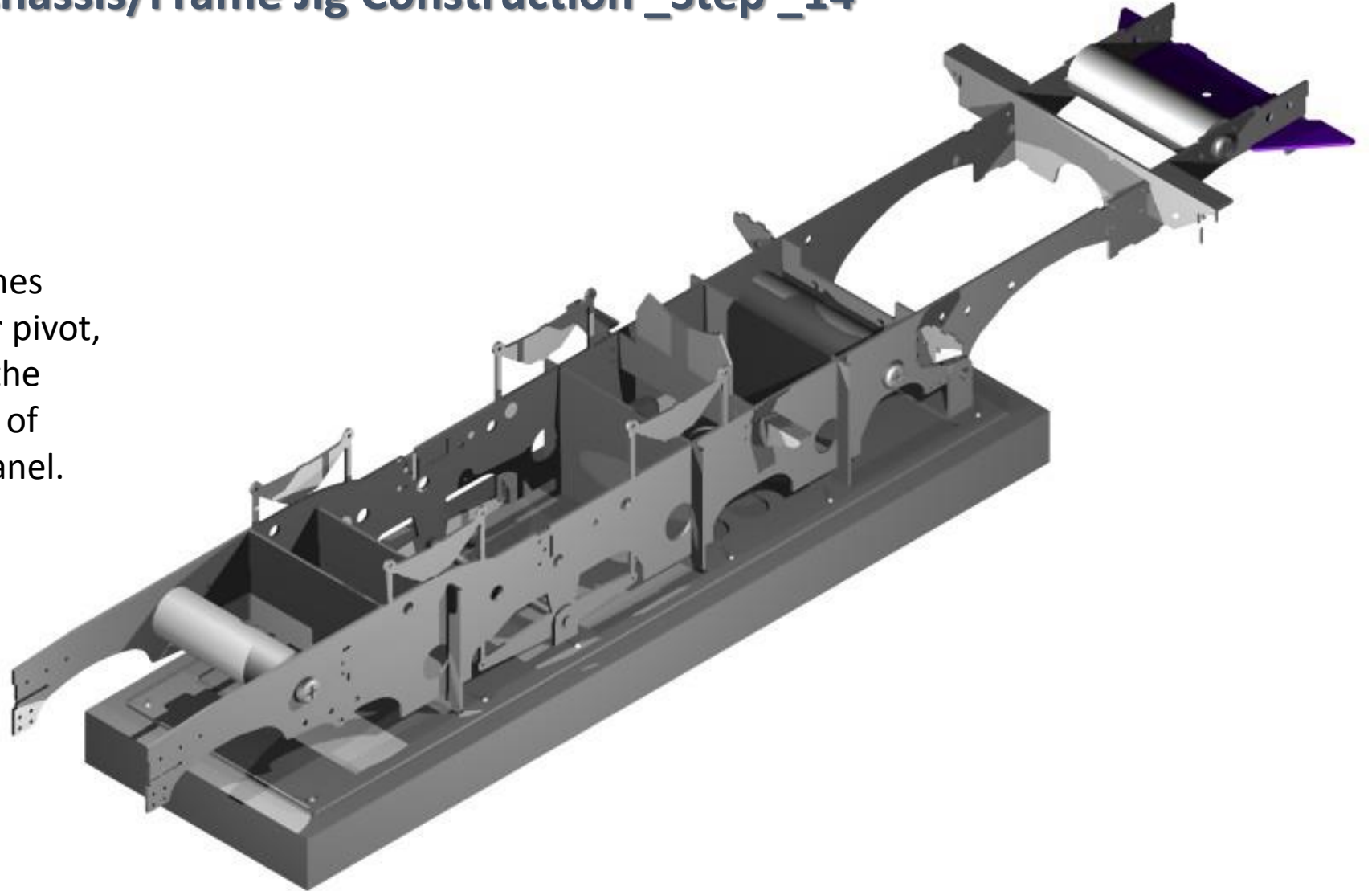

# NSWGR Z20 7mm Tank Loco Kit

## Chassis/Frame Jig Construction \_Step \_15

Panel 6 is the buffer panel that should fit neatly into the tabs of the frame and sit flush with the frame ends.

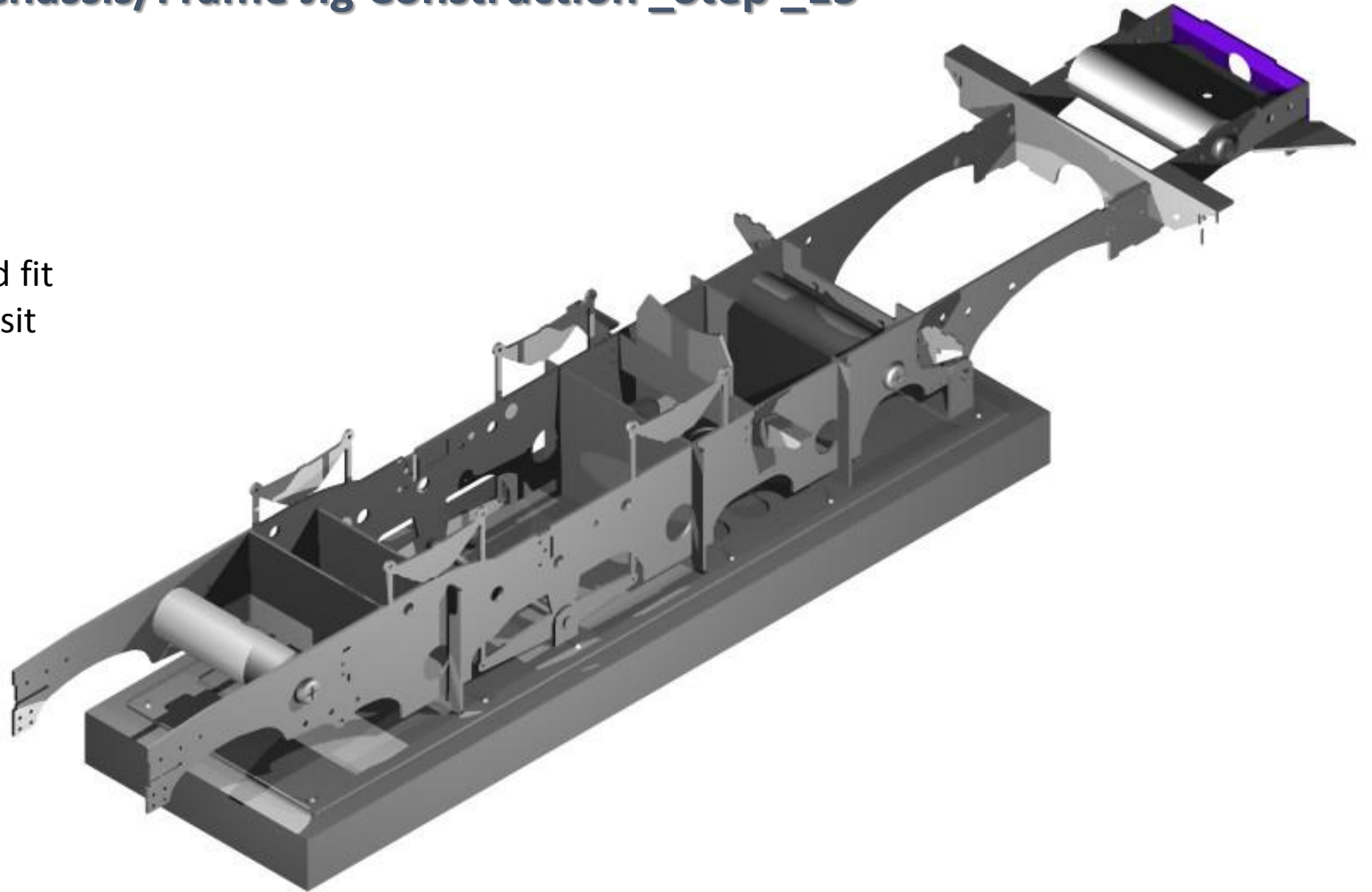

# NSWGR Z20 7mm Tank Loco Kit

## Chassis/Frame Jig Construction \_Step \_16

Panel 7 is a fill in panel on the rear of the frames to allow the coupler to sit at the correct height.

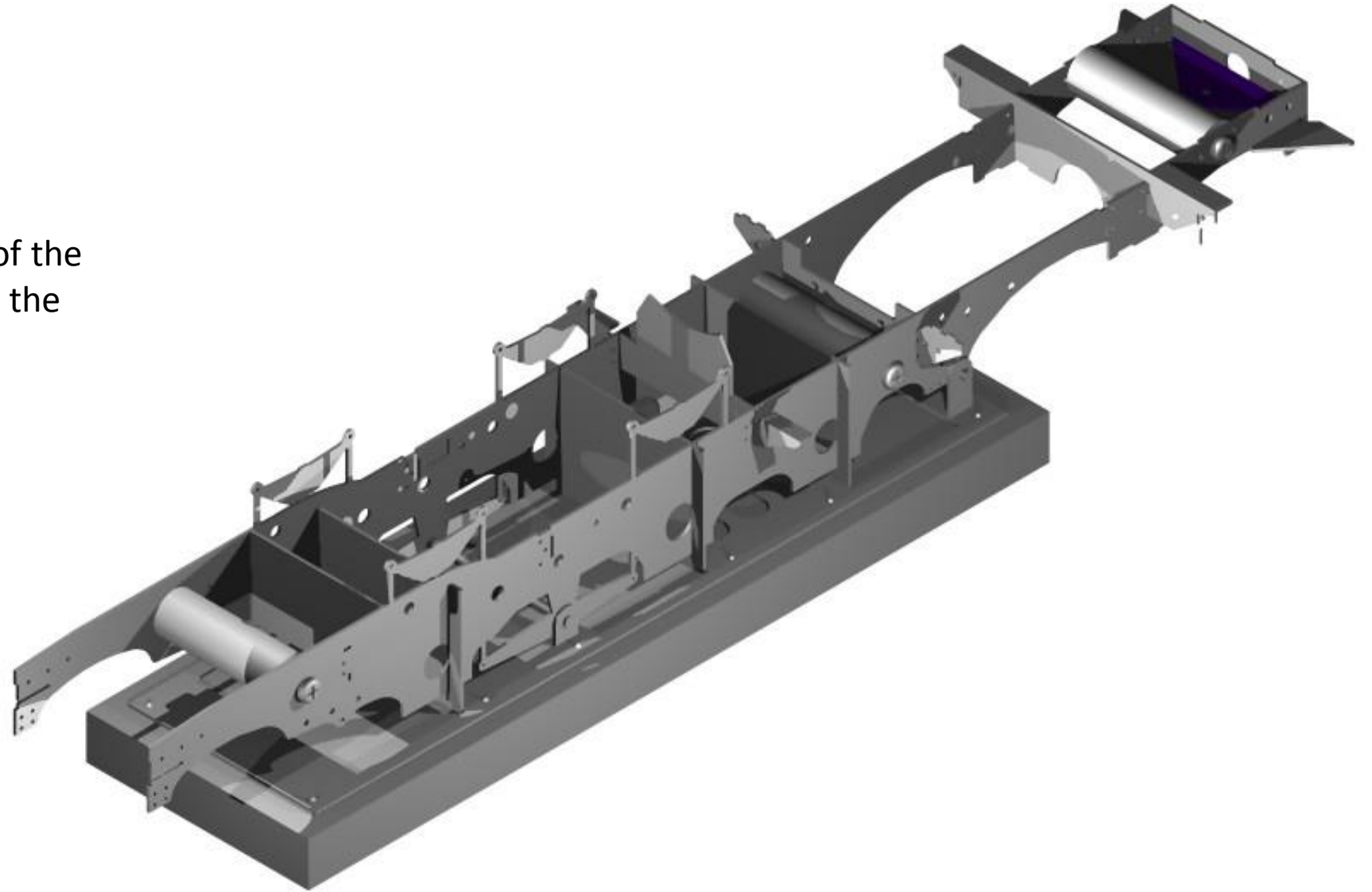

# NSWGR Z20 7mm Tank Loco Kit

## Chassis/Frame Jig Construction \_Step \_17

Panel 8 is similar to panel 5, and should be flush with the front of the frames with small tabs protruding through to accommodate the buffer plate.

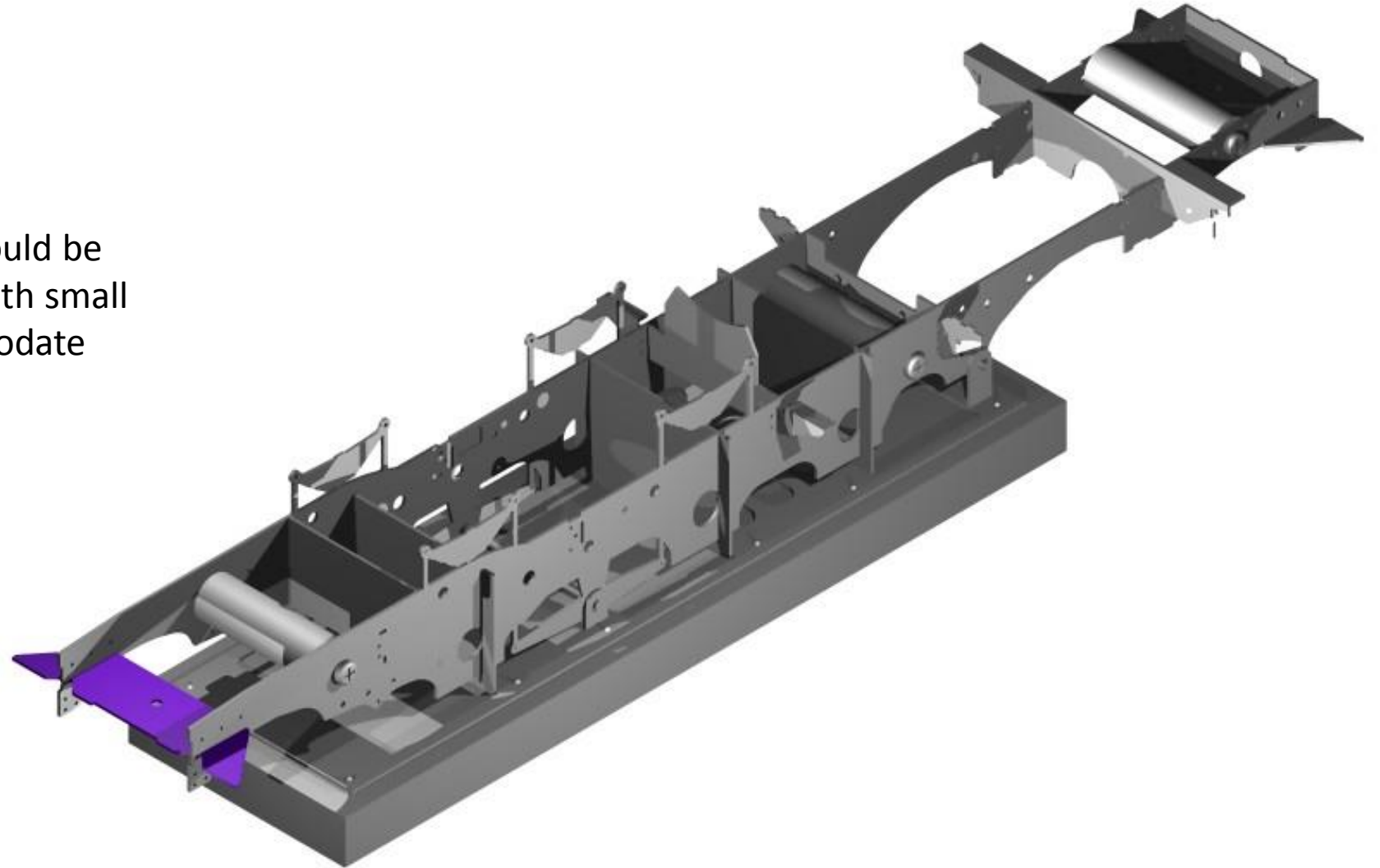

# NSWGR Z20 7mm Tank Loco Kit

## Chassis/Frame Jig Construction \_Step \_18

Panel 9 is the buffer plate that sits into the slots and flush with the end of the frames.

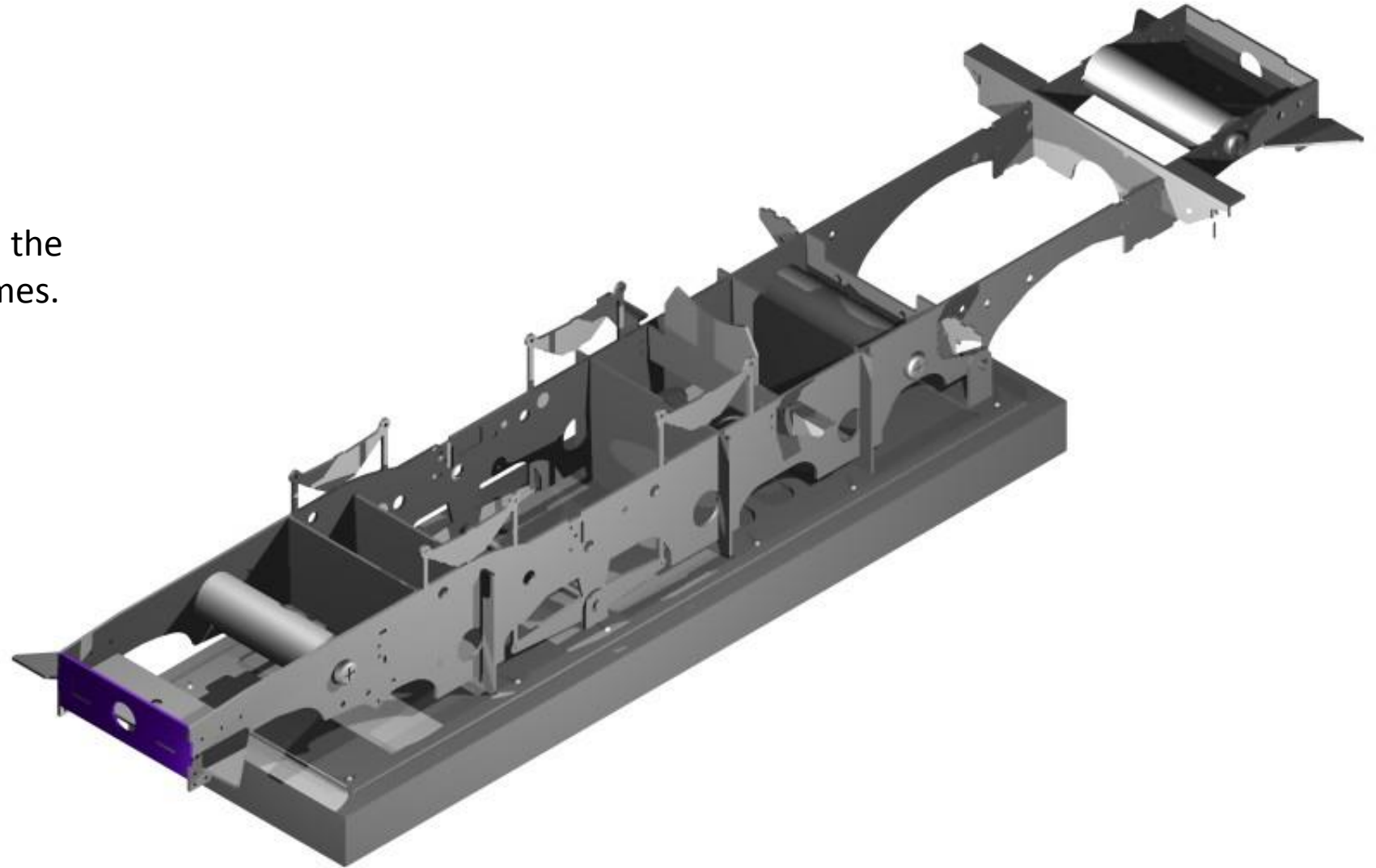

# NSWGR Z20 7mm Tank Loco Kit

## Chassis/Frame Jig Construction \_Step \_19

Once these panels are located the frame can be removed from the jig as it should be square and level.

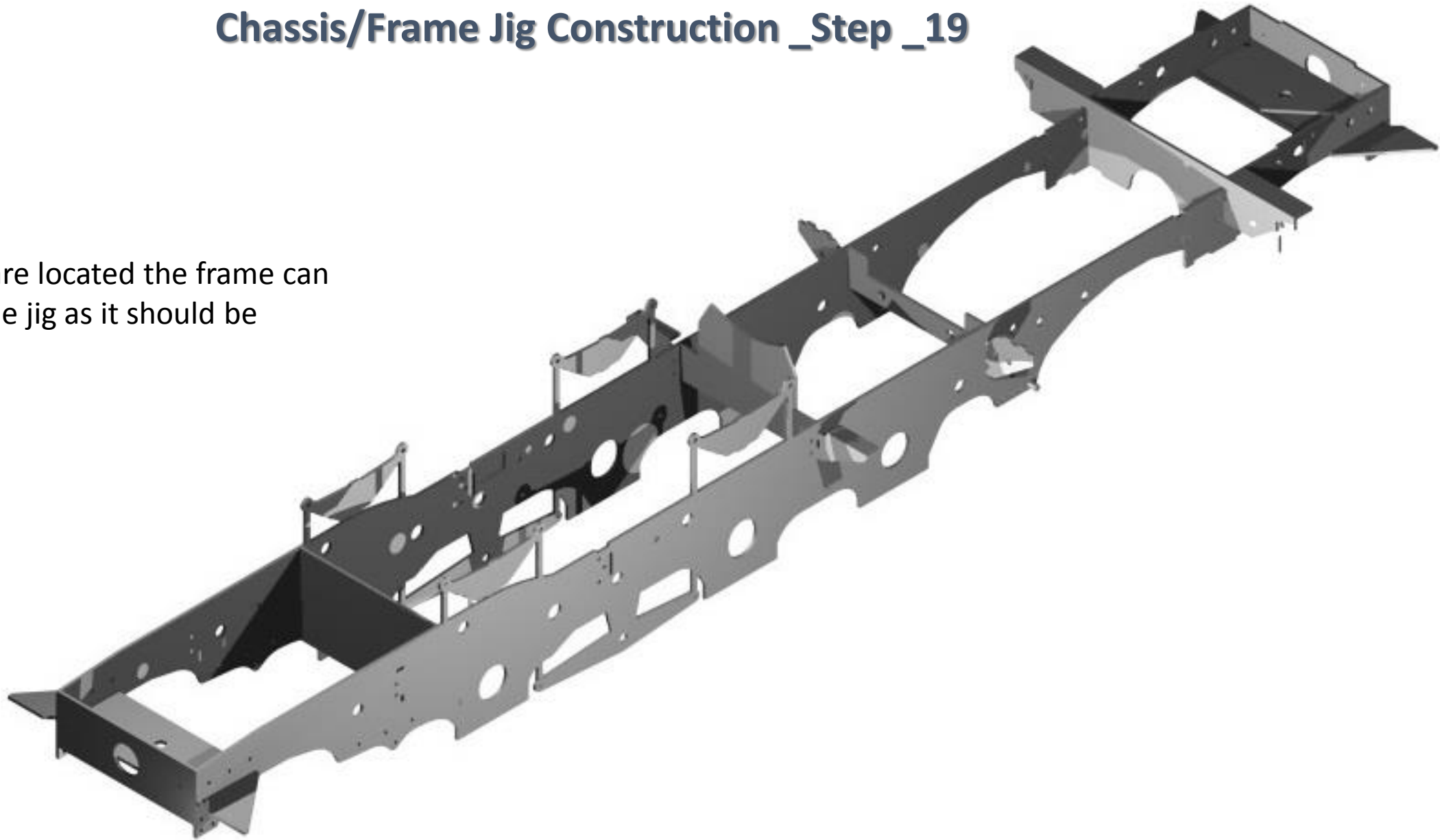

# NSWGR Z20 7mm Tank Loco Kit

## Chassis/Frame Jig Construction \_Step \_20

**This is just a demo to show how the instructions will be provided in this kit, and this instruction will be upgraded as parts arrive and the pilot build is completed.**

**Much more to come.**